

# A GLOSSARY OF MEMORIAL TERMS

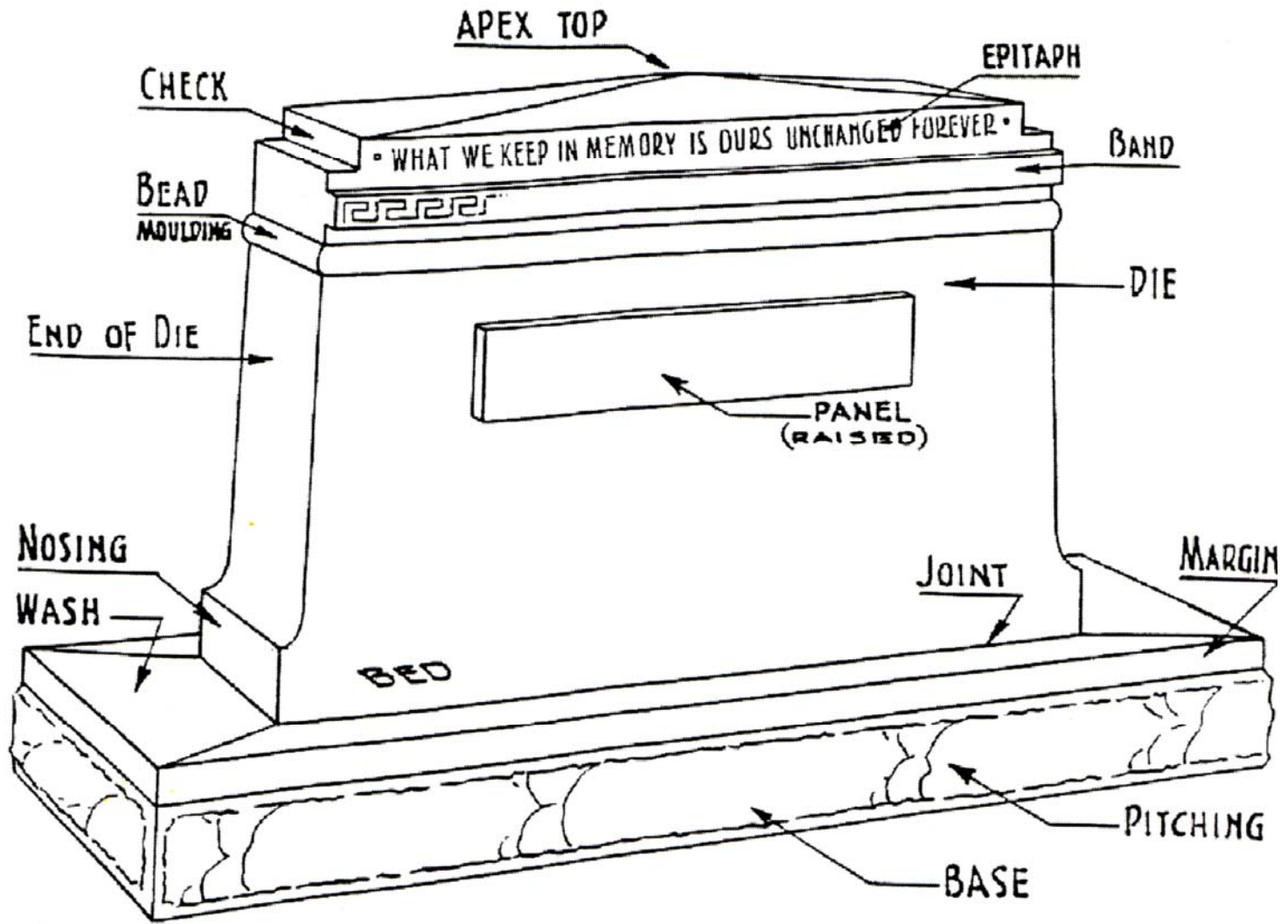

## STYLES OF LETTERING



OUTLINE LETTER



SANDBLAST SUNK

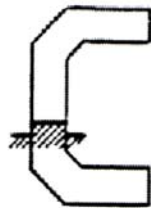

SQUARE RAISED



ROUND RAISED

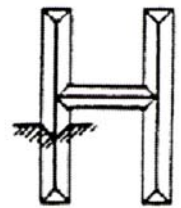

V - SUNK

## TOPS OF DIE CONTOURS

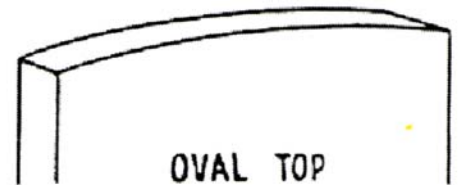

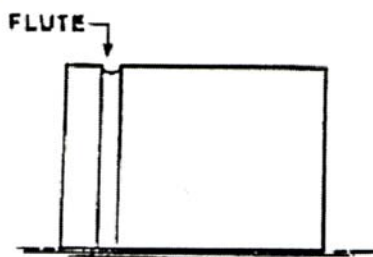
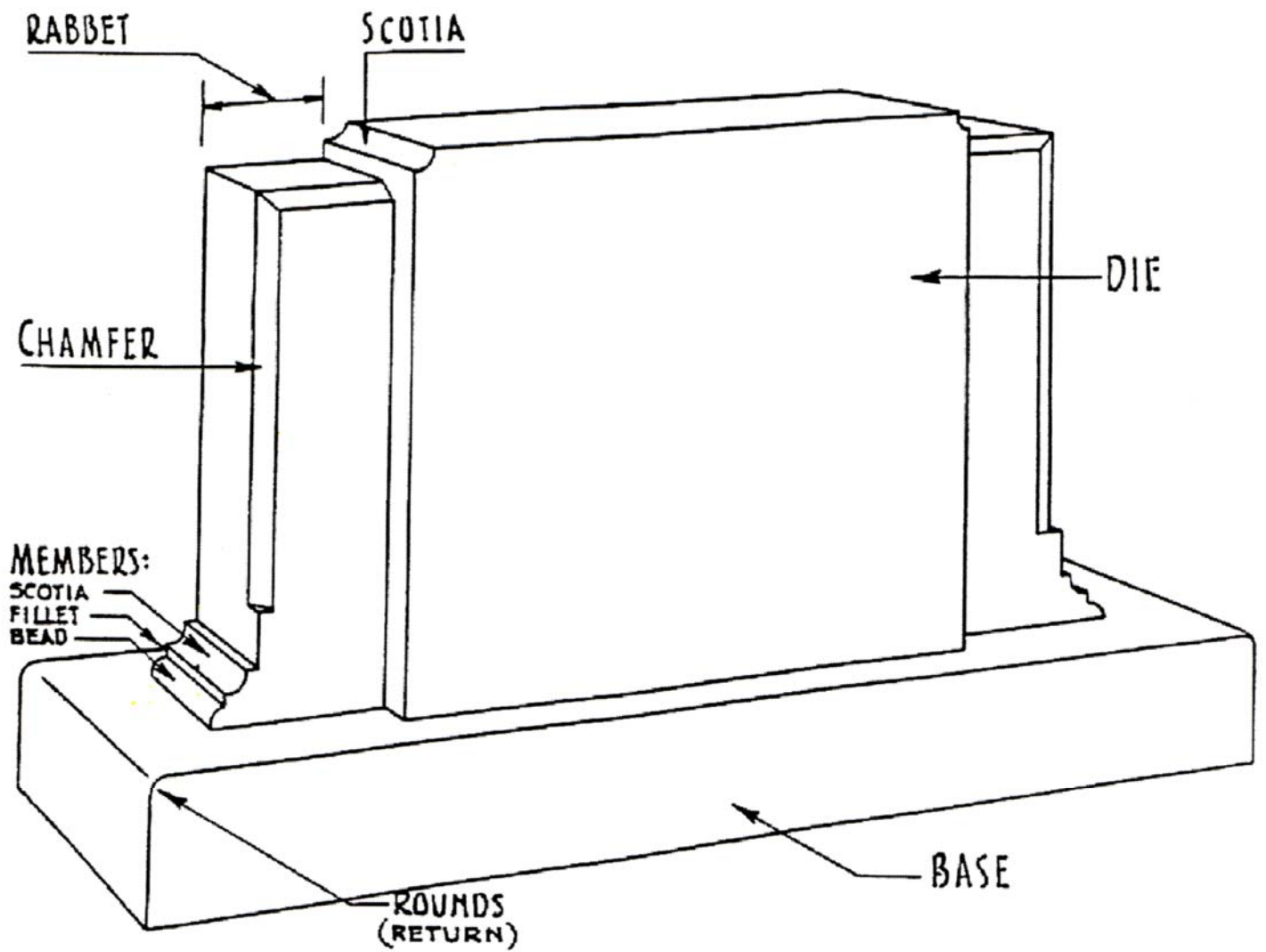

**MONOLITH**  
A MEMORIAL DESIGNED  
WITHOUT A BASE

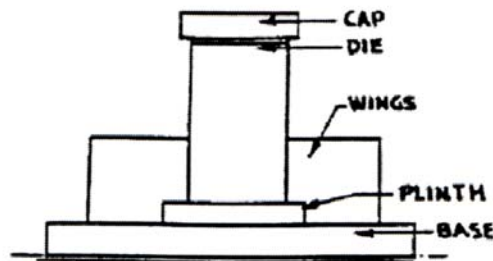

**SCREEN MEMORIAL**



**CINERARY URN**  
WITH COVER



**VASE**  
CORED FOR  
PLANTING

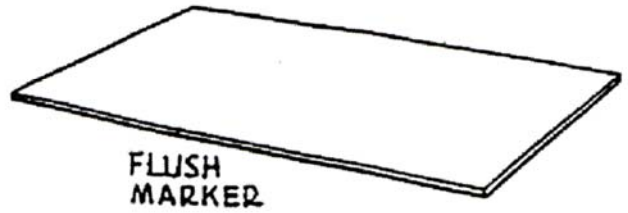

FLUSH  
MARKER

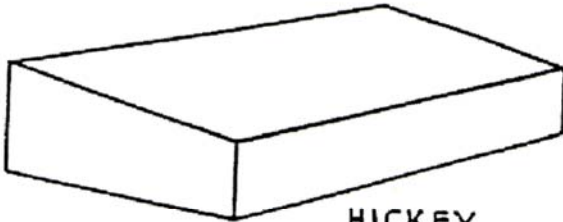

HICKEY  
(BEVEL) MARKER

NOSING

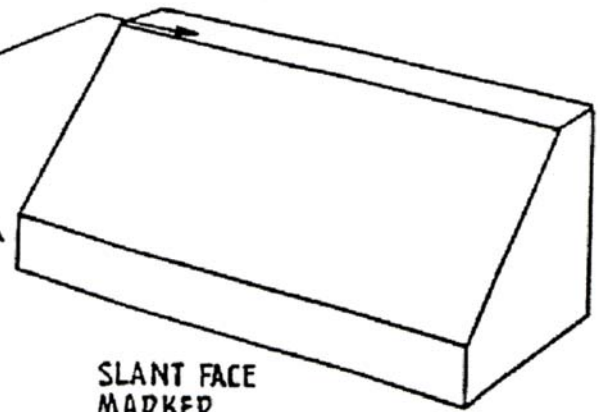

SLANT FACE  
MARKER

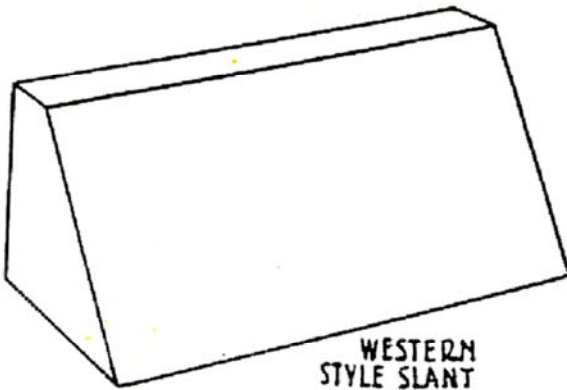

WESTERN  
STYLE SLANT  
MARKER

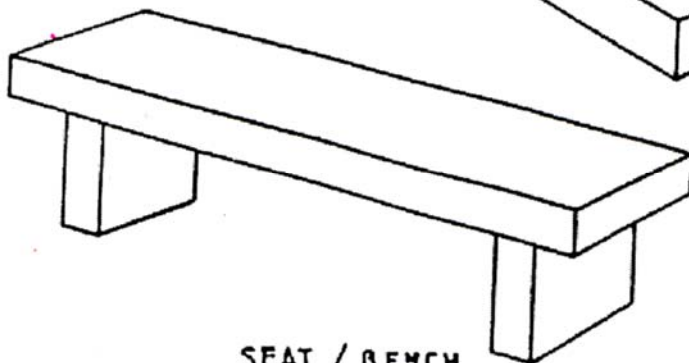

SEAT / BENCH

## DESCRIPTION OF STONE FINISHES

### "POLISHED"

A dark, mirror-gloss finish, made with felt buffer and tin oxide.

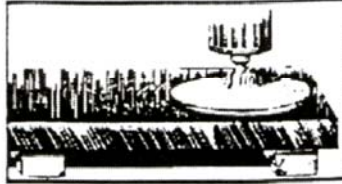

### "THERMAL"

A rough, random-texture finish created by spalling with high-temperature gas flames.

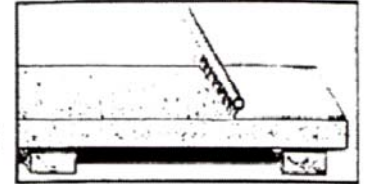

### "HONED"

A dark, smooth finish, ground with carborundum wheel or loose abrasive and water.



### "AXED"

A wide variety of smooth and textured patterns made by pneumatic hammers and steel chisels.



### "STEELED"

A light, smooth finish, from grinding with iron wheel and chilled shot.

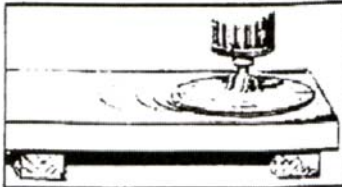

### "ROCK-PITCHED"

A hand-cut rustic finish with edges dressed to a straight line.



### "METRO-STEELED"

A light, smooth finish by sand blasting with fine chilled shot.



### "SHELL ROCK"

A hand-cut rustic surface with strong, scalloped or dish shaped appearance.

